

VERIS Verabar®

Power and Plant Utilities

Duct Air Flow



APPLICATION GUIDE

Steam Drum

Platen
Secondary
Superheater

Secondary
Superheater

Reheat
Superheater

Convection
Pass

Reheat
Superheater

Primary
Superheater

Economizer

Furnace

NO_x
Ports

Primary
Air Duct

Tempering
Air Duct

From
Forced
Draft
Fan

Verabar... A New Idea in Duct Air Flow Measurement

The Veris Verabar is designed to be the most reliable, accurate and repeatable method of measuring volumetric or mass airflow in round and rectangular ducts. In power and plant utility measurement, the Verabar delivers precise control of combustion airflow to ensure proper fuel to air ratios yielding more stable and complete combustion. This minimizes NO_x and CO emissions and optimizes plant performance.

Critical Combustion Airflow Applications

- Primary Air
- Secondary Air
- Overfire Air
- Individual Burner Air
- Flue Gas
- Recirculating Flue Gas Flow
- Selective Catalytic Reduction

Problems Associated with Previous Measurement Technologies

Airfoil — High permanent pressure loss, difficult to install and maintain, prone to clogging and questionable accuracy due to lack of test data.

Thermal Dispersion — Requires testing and calibration at different flow rates, no means of checking calibration and can cause excessive downtime due to particulate build-up and corrosion.

Averaging Pitot Array — Difficult to install requiring cutting out duct sections, low differential pressure signal, prone to clogging of sensor ports and no test data to support accuracy and straight run claims.

Higher Accuracy in Square and Rectangular Ducts

The Verabar flow calculation program adjusts the flow coefficient to compensate for the higher drag in the corners of the duct.

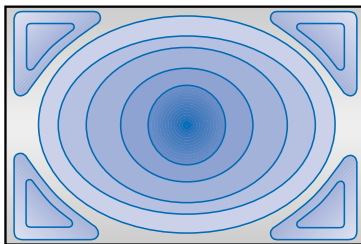

Verabar Accuracy Verified by Independent Tests

Independent flow tests verified the Analytical Model and predicted flow coefficients within $\pm 1/2$ Percent

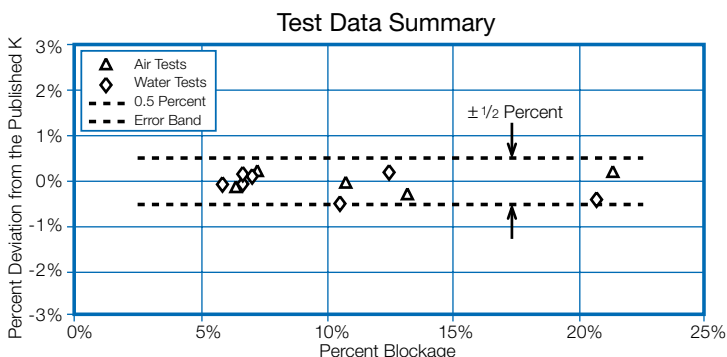

The Verabar Solution

The Verabar is guaranteed for 5 years to deliver outstanding performance even in the most hostile environments.

- High temperatures up to 1000°F (540°C)
- Heavy particulate without requiring a purge system
- Moisture laden air
- Corrosive atmospheres

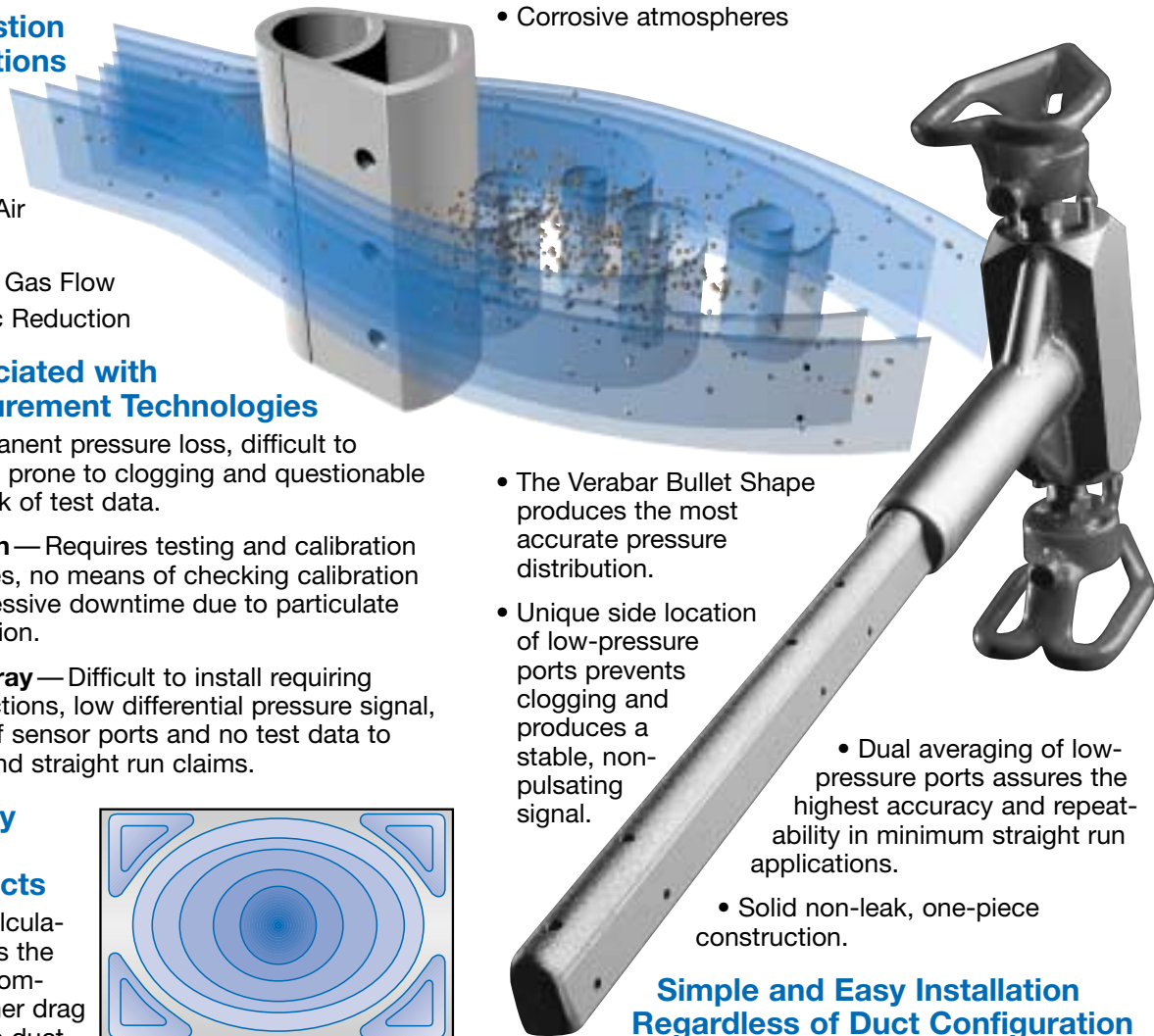

- The Verabar Bullet Shape produces the most accurate pressure distribution.

- Unique side location of low-pressure ports prevents clogging and produces a stable, non-pulsating signal.

- Dual averaging of low-pressure ports assures the highest accuracy and repeatability in minimum straight run applications.

- Solid non-leak, one-piece construction.

Simple and Easy Installation Regardless of Duct Configuration

Depending on the size and shape of the duct, one or two Verabars can be directly inserted through a simple weld coupling. No cutting of the duct is required.

Veris engineers are available to assist in determining the exact location for maximum performance even in the most difficult short straight-run duct configurations.

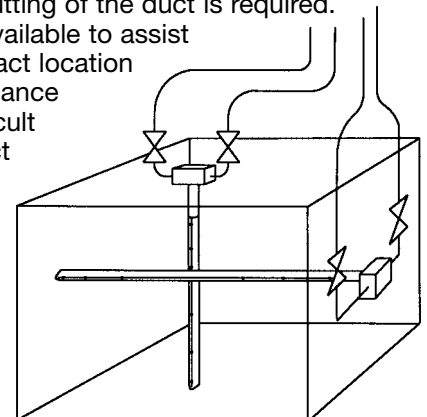

Verabar provides easy installation from top, bottom or side.

Combustion Air Duct Application

Verabars Installed in Power Plant—Huang Pu, China

One of the largest power plants in the world located in Huang Pu, China supplies approximately 30% of the

power to Hong Kong. Verabar flow sensors were installed in 2000mm x 3000mm (80" x 120") rectangular combustion air ducts. Two Verabars were installed in the six combustion air ducts due to the limited upstream straight-run of less than 2 diameters (Figure 1). The Verabars were manifolded to a single DP transmitter.

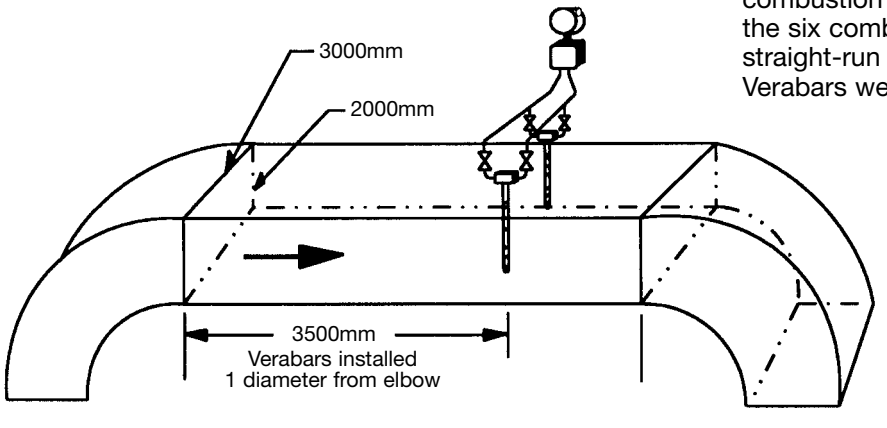
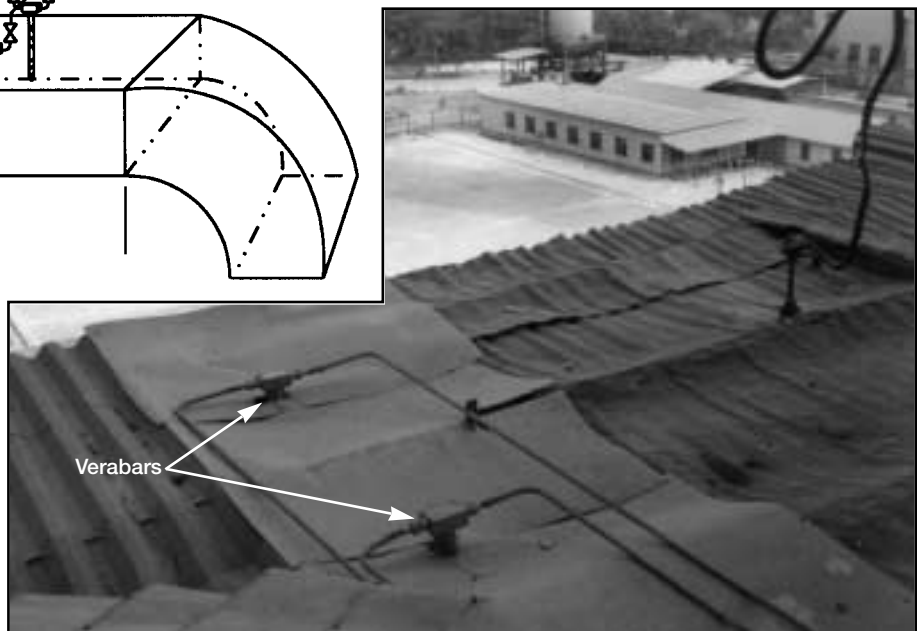

Figure 1
Installation for duct air flow in
Huang Pu Power Plant



Operating Cost Savings

The engineers reported that the Verabars improved accuracy, repeatability and greatly improved combustion control, which resulted in a significant reduction in NO_x and CO emissions. Also, the Verabars did not require purging. An additional benefit was a documented yearly fuel savings of \$291,250.

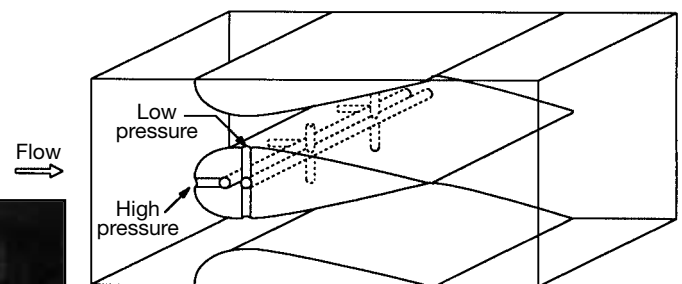

Figure 2
Old airfoils

Verabars Replace Airfoils

Verabars replaced the old airfoils for primary air measurement (Figure 2). Airfoils fabricated in a duct section create a high permanent pressure loss and restrict the air flow. Their accuracy and repeatability is poor (no test data to determine flow coefficients). In addition, airfoils require frequent expensive maintenance and purging, greatly reducing the efficiency of the automated combustion control system.

Versatile Verabar® Installations

Flue Gas Navajo Scrubber Project — Arizona, USA

Verabar flow sensors (Figure 3) are installed in 22' (6.7m) ducts to determine efficiency and to balance the flow in three sets of twin-tower scrubbers at the Navajo Generating Station, one of the largest new-generation coal fired power plants in the country. The project was engineered by Stone & Webster and is operated by a consortium of utilities and the Federal Government.



Figure 3
One of the 22-foot Verabars installed in the Navajo Generating Station

Three 22-foot Verabars were installed in each duct (18 sensors in all). The three Verabars were manifolded together to average the entire flow in each duct. Special features include center support sleeves and rear support struts, which enable the Verabars to span the 22-foot ducts. Custom mounting hardware was also engineered and manufactured by Veris (Figure 3).

The Verabar's resistance to clogging is a big plus in this application due to the existence of fly ash in the flow. As a backup, six purge systems were installed (Figure 4). Each purge system supplies air to three separate Verabars.



Figure 4
Purge system

Primary, Secondary and Fluidizing Air — Alstom Energy Systems (France) & Bechtel USA

Alstom Energy Systems in France, in conjunction with Bechtel USA, specified 96 Verabar flow sensors for the Red Hills Generating Station in Mississippi. Applications include primary air, secondary air and fluidizing air. Pipe/duct sizes range from 4" to 75" (100mm to 1900mm).

While most of the sensors supplied were standard catalog items, special engineering was required for several of

the longer sensors. Because the opposite end of the ducts was not accessible, it was not possible to install opposite end supports for the sensors. Veris designed a special spring lock flanged sensor (Figure 5) that pins the sensor against the opposite wall, removing the need for opposite end support.

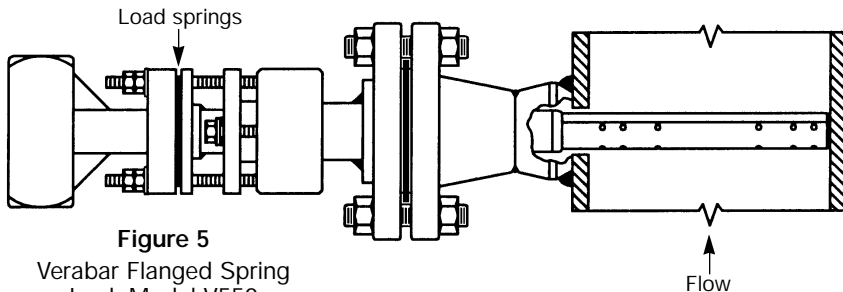

Figure 5
Verabar Flanged Spring Lock Model V550

For Immediate Service Use

FASTER

Factory Assisted Service & Technical Response

U.S. and Canada
Call Toll Free:

1-877-VERIS00
(1-877-837-4700)

Contact Veris Worldwide:

Tel: (303) 652-8550
Fax: (303) 652-8552

E-mail: contact@veris-inc.com
Website: www.veris-inc.com



VERIS, inc.

Verabar... Engineered for the Power Industry